

Copyright © SUTER Industries AG / Mettlenstrasse 3 / CH-8488 Turbenthal. Fuer dieses Dokument behalten wir uns alle Rechte vor. / We reserve all rights in connection with this document.
CAD System: CATIA

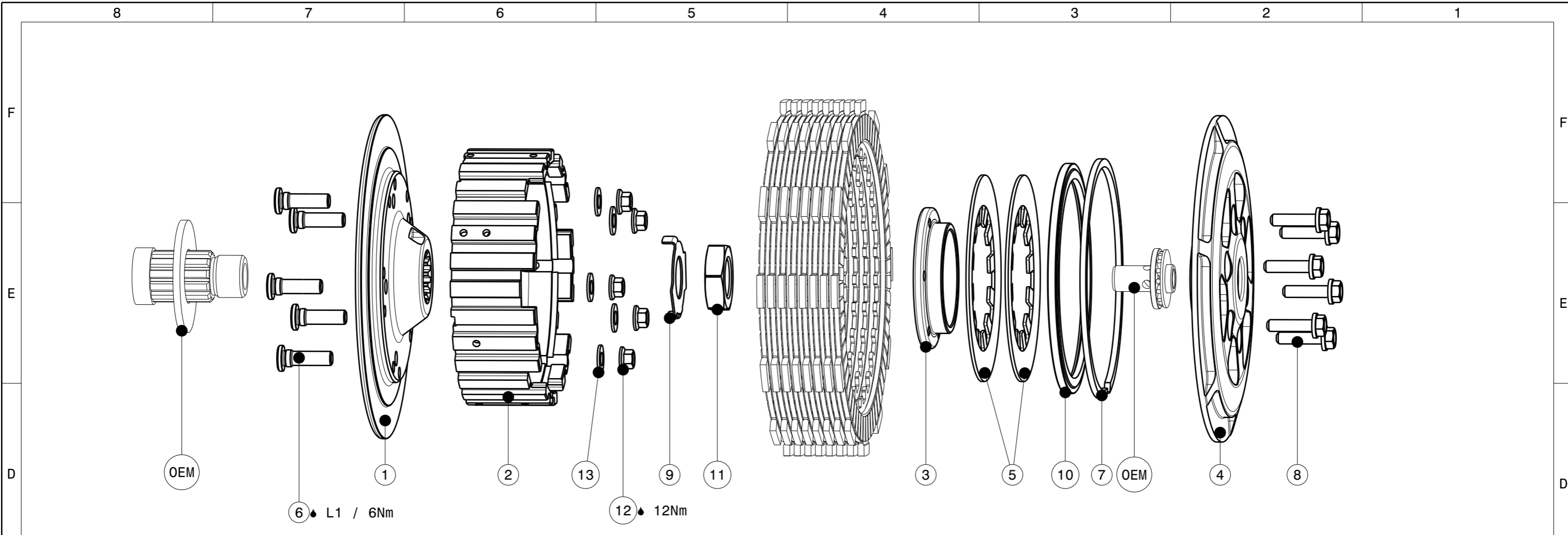

ITEM	PART NAME	SRT NUMBER	QTY
1	Back Plate PD	004-42722	1
2	Inner Hub	004-21741	1
3	Clamp Hub 7.0mm	004-00507	1
4	Pressure Plate	004-42944	1
5	Disk Spring Main ø88 700N	004-88070	2
6	Stud Bolt M6	004-12980	5
7	Circlip 100mm	004-17833	1
8	Hex. Head Bolt M5x20	999-110205020	6
10	Locking Ring 98	004-00698	1
12	Nut M6	999-12030605	5
13	Washer M6	BN1976-6x12x1.0	5
INSTALLATION MATERIAL			
9	Locking Washer 18/31/0.7mm	004-00673	1
11	Nut M18x1.5	004-998181580	1
ADDITIONAL MATERIAL			
	SuterClutch packing compl. 2017	004-52042	1
	Sticker SuterClutch 7x1.5cm	004-52050	2
	Sticker SuterClutch 15x3.3cm	004-52051	2
	Installation Manual SuterClutch	004-52060	1
	Drawing "Kunde"	-	1

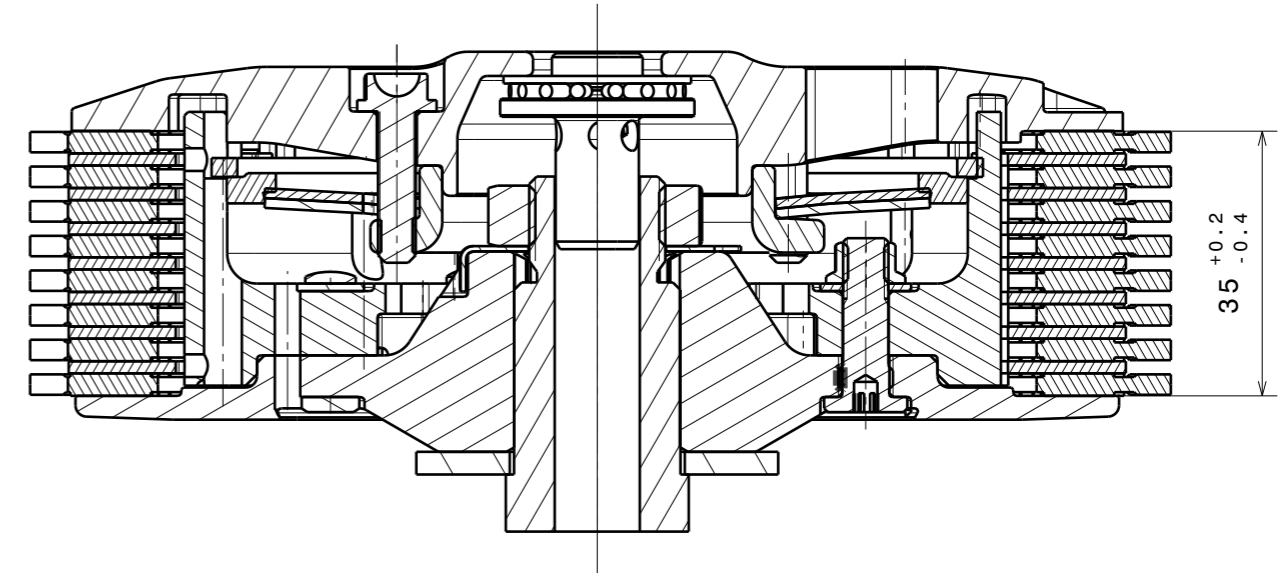

Fehlende Masse und Angaben sind dem 3D-CAD-Datensatz zu entnehmen
For missing dimensions and details see 3D-CAD data set

Werkstoff (DIN) / Material (DIN) SEE PARTLIST	Oberfläche/Surface DIN ISO 1302	Kantenbruch / break edges ISO 13715	Toleranzangabe / Tolerance DIN ISO 2768 - mK DIN EN ISO 13920 - BF		Anzahl Prüfmerkmale / Number inspection characteristics 0			
Zertifikat / Attest R <input type="checkbox"/> O <input type="checkbox"/> K <input type="checkbox"/> H <input type="checkbox"/>	Massstab/Scale 1:1		Gewicht/Weight 1588g	Format A3	Blatt/Sheet 1/2	Prüflos / inspection lot [%] Q-Level / Level of quality L5		
Datum/Date 05.10.2023		Name t.kuhn		Gezeichnet/ designed		Geprüft/ checked 05.10.2023 f.kunz		
Freigegeben/ approved 05.10.2023		Name t.kuhn		Artikel Nr. / Part No. 004-42050		Rev. 0		
SUTER INDUSTRIES			SuterClutch MX-Line TM 250/300 2T 2019-2024				SuterClutch MX-Line TM 250/300 2T 2019-2024	

004-42050-0 SuterClutch TM 250/300 2T

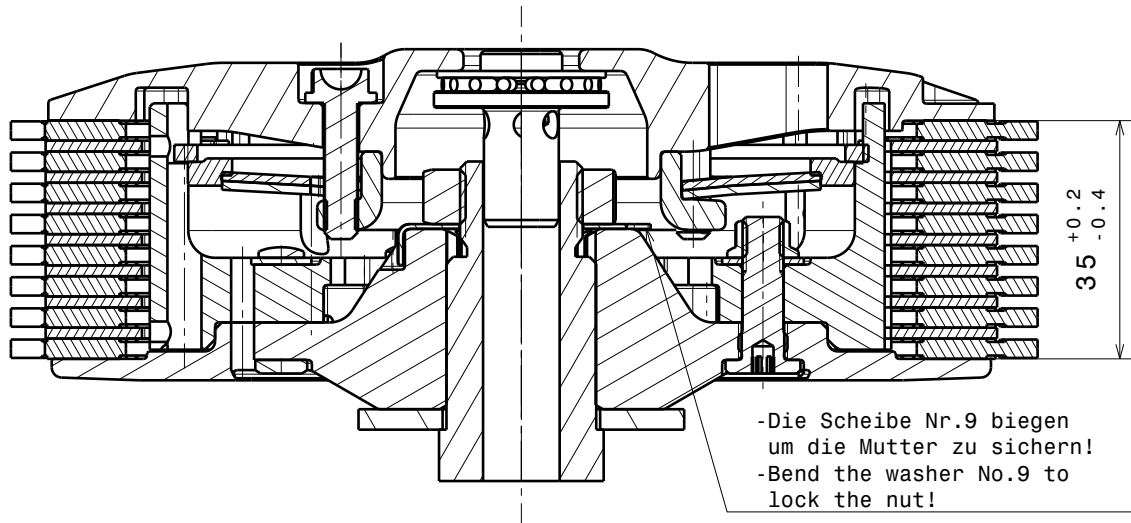
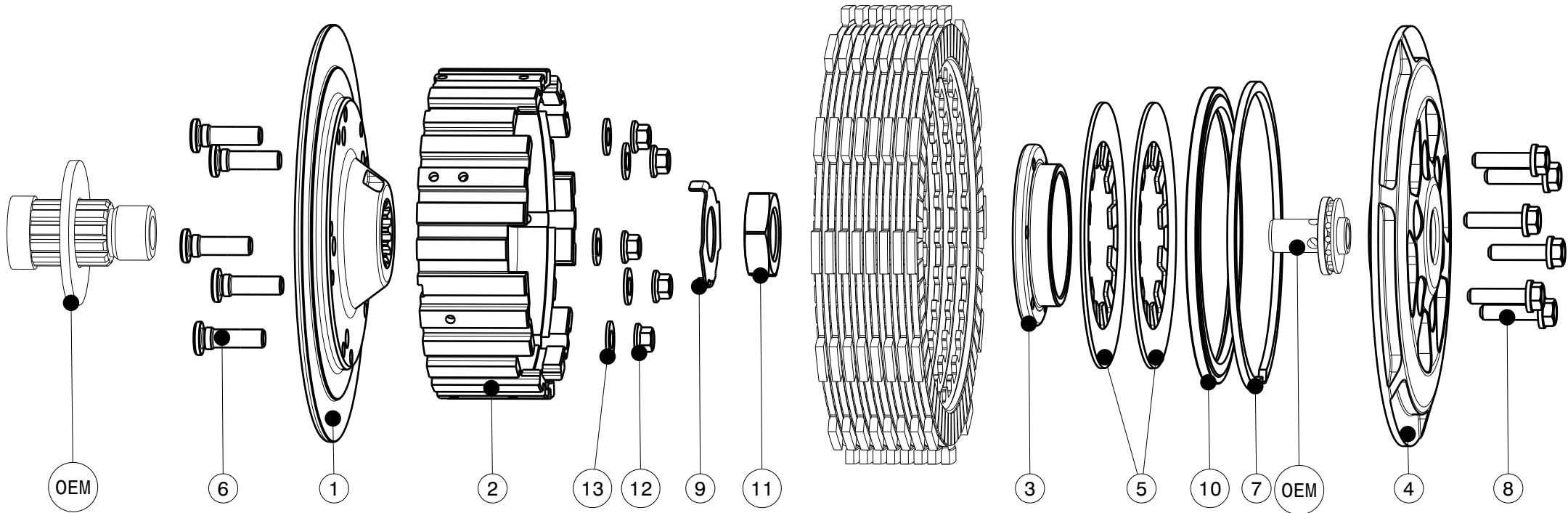

ITEM	PART NAME	SRT NUMBER	QTY
1	Back Plate PD	004-42722	1
2	Inner Hub	004-21741	1
3	Clamp Hub 7.0mm	004-00507	1
4	Pressure Plate	004-42944	1
5	Disk Spring Main ø88 700N	004-88070	2
6	Stud Bolt M6	004-12980	5
7	Circlip 100mm	004-17833	1
8	Hex. Head Bolt M5x20	999-110205020	6
9	Locking Washer 18/31/0.7mm	004-00673	1
10	Locking Ring 98	004-00698	1
11	Nut M18x1.5	004-998181580	1
12	Nut M6	999-12030605	5
13	Washer M6	BN1976-6x12x1.0	5

Das angegebene Belagspaketmass ist zwingend einzuhalten!
The plate package thickness must be strictly adhered to!